



Dotpeenator™ SA14 Dot Peen Marking Machine

Discover
the potential



Türk Mali



ISO9001:2008

Dotpeenator™



Dotpeenator SA14

Dotpeenator™

160X110MM



www.dotpeenator.com

Dotpeenator™ SA14 Dot Peen Marking Machine



- Easy Start-Up
- Pneumatic
- Long-Lasting
- Double Column
- Cast Iron Work Table
- Powerful & Accurate
- Heavy & Robust
- Touch Screen

Dot Peen Marking Machine

SA14



Specifications of Dotpeenator™ SA14

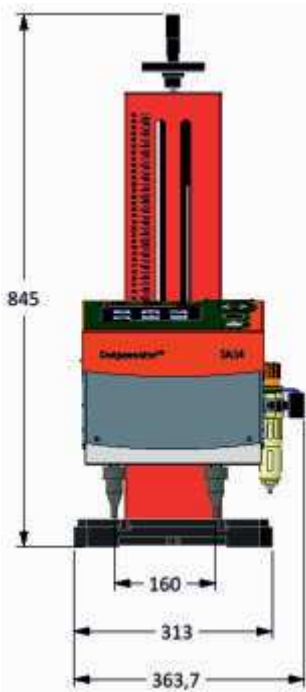

- Sa144 Dot Peen Marking Head with 160X110mm Marking Area
- X&Y Linear Guide Ways
- High Accuracy & Precision
- Stainless Steel X&Y Axes Dust Covers
- Air Regulator
- Remote START & STOP Controller
- 7 inch TFT Color Touch Screen
- Linux Based Control Unit
- Linux Based Dotpeenator™ Marking Software
- Data Transfer
- Shift Marking
- Custom-Made Date Coding with Characters
- Create-Your-Own-Fonts Module
- Connection With A Host Computer
- Database connection
- 3 USB Ports
- 1 RS232 Port
- Integrated I/O Port
- Working with Keyboard & Mouse
- PLT Extended Vector Marking
- Setting Peen Tracing Points of Work Pieces
- Linear ve Arc Scale Marking
- 2D Data Matrix Marking
- Setting a Peen Docking Point
- Setting Dot Intervals on the

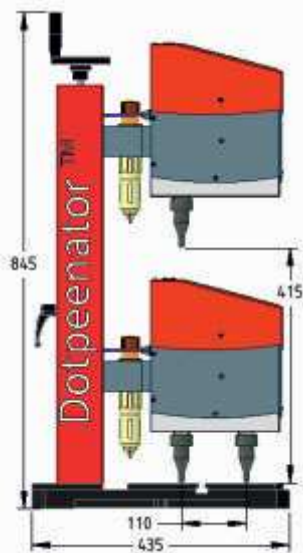

- Dotpeenator™ Dot Peen Marking Software
- Circumferential Marking by an External Optional Rotary Axis
- Circumferential Letter by Letter, Word by Word, Sentence by Sentence Marking
- Selective Button for Vibro Peen Assemblies and Long-Stroke Deep Marking Peen Assemblies
- Date, Time, Shift, Julian Calendar, Day of Week, Week Number, Name of Day Marking
- Static Content Marking
- Vehicle Chassis Marking
- Random Code Marking
- Barcode Marking From a Barcode Reader
- T-Slotted Cast Iron Work Table
- X Limit Led
- Y Limit Led
- Z Limit Led
- Power Led
- Marking Led
- Work-Area Illumination Led
- USB Connection Cable
- Power Cable
- Optional 9 Pin Rs232 Connection Cable
- Many Others

Optional Accessories for Dotpeenator™ SA14

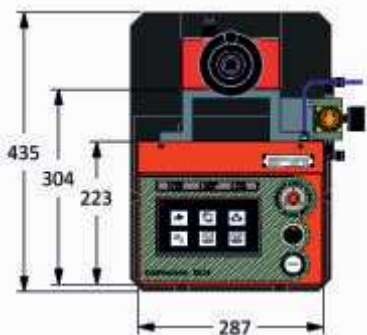

- 5-Size Peen Assembly Kits Tolerating Irregular Surfaces upto 12mm at upto 2000 kgfs
- 5 Size High Speed Vibro Assembly Kits
- Rotary Axis with 80mm Gauge Mechanical Chuck
- Rotary Axis with 80mm Gauge Pneumatic Chuck
- Rotary Axis with 100mm Gauge Mechanical Chuck
- Rotary Axis with 100mm Gauge Pneumatic Chuck
- Rotary Table & Special Custom Fixtures
- Programmable Z Axis
- Manual & Programmable C Axis
- Name Plate Vise
- Automatic Name Plate Feeding System
- Fixed & Hand-Held 2D Data Matrix Readers